

PRECISION

Precision Hydraulic Expanded Chucks and Arbors

Standard Tolerances of .0005" T.I.F.

CAMERON



Certified to
ISO 9001:2015

Cameron

A CAMERON COMPANY

Special Standard Features

- Standard Tolerances of .0002" T.I.R.
- Completely Repairable if Damaged or Worn.
- Can Be Actuated Manually, Using Machine Drawbar, and/or External Hydraulic Source.
- Unusual Flexibility : .006"-.008" Average Expansion Provided*
- Positive Oil Retention
- Durability and Accuracy for Rough Machining to Final Inspection.

* Expansion Varies on Size Requirement



Cameron

A SPEEDGRIP COMPANY

THE WORKHOLDING PRINCIPLE

The Cameron Hydraulic Arbor and Chuck Workholding Principle was developed by experienced work-holding specialists to fill the need for simple, high-accuracy positive gripping chucks and arbors – tools which would give reliable performance and avoid breakage even in unskilled hands.

The unique metal flexing principle and patented sealing system for medium hydraulic actuating oil does it differently and better. Accidental tool breakage, minimal expansion and leakage, so characteristic of standard "grease-actuated" thin sleeved tools are practically eliminated.

The chuck and arbor shells are thicker, 3/16" minimum. They are spring tempered hardened and ground to a precision fit.

Cameron's design is so simple and rugged that they will tolerate several times the normal "safe" expansion even without a workpiece. No moving parts means no wear and no concentricity loss.

Hollow-ground gripping surfaces straighten and hold the part in exact coincidence of centerline. No other hydraulic tool does this. Reliable repeatability and unusual gripping strength naturally result.

Cameron tools use medium grade hydraulic oil which allows fast return to normal even after extreme expansion. They can be actuated manually or automatically through mechanical means or by use of the machine hydraulics pressure using a standard Cameron Intensifier (illustrated on the following pages).

Cameron is always pleased to share its expertise with its customers. However, when making inquiries about chucking applications for various parts, it is essential that the customer supply prints or the parts to be machined. It is also important that we know the style machine on which the chuck or arbor is to be used, and how it is to be actuated (manually, automatically or intensifier).

Concentricity requirements must also be specified.

In brief Cameron tools Offer:

1. Simple, fast action.
2. No moving parts – no concentricity loss from internal wear.
3. Assured repeatability and unusual flexibility.
4. Greater gripping power.
5. Positive oil retention.
6. Durability and accuracy for rough machining to final inspection.

Let us demonstrate these advantages in your own plant, at your convenience.

RELAXED POSITION

Hollow Ground Concept

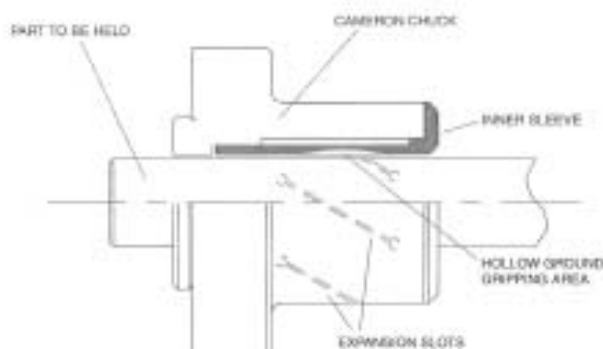

The relaxed tool has ample clearance for easy load and unload of the work part.

INITIAL CONTACT

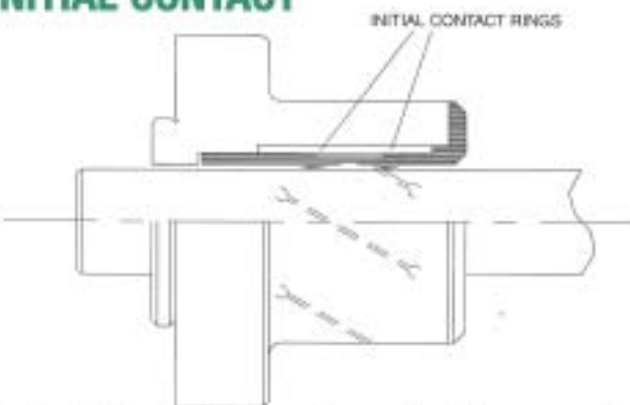

As the tool is actuated, two rings on the hollow-ground gripping area make contact with the part, straightening and centering it automatically.

CLAMP POSITION

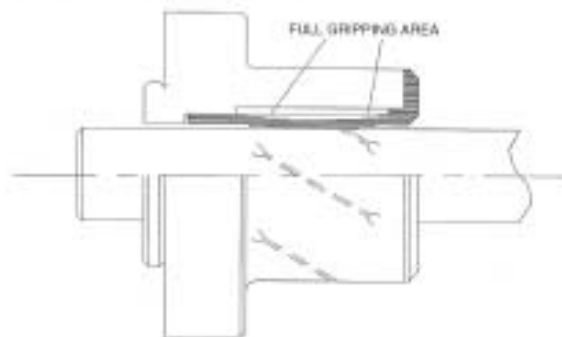

Full actuation causes the slotted shell to hold the part with its full gripping area. Parts are held firmly and accurately for any machining or gaging operation.

CHUCKS AND ARBORS

DUAL DIAMETER GRIP ARBOR

Drawbar Actuated – Mounted to A2 Spindle

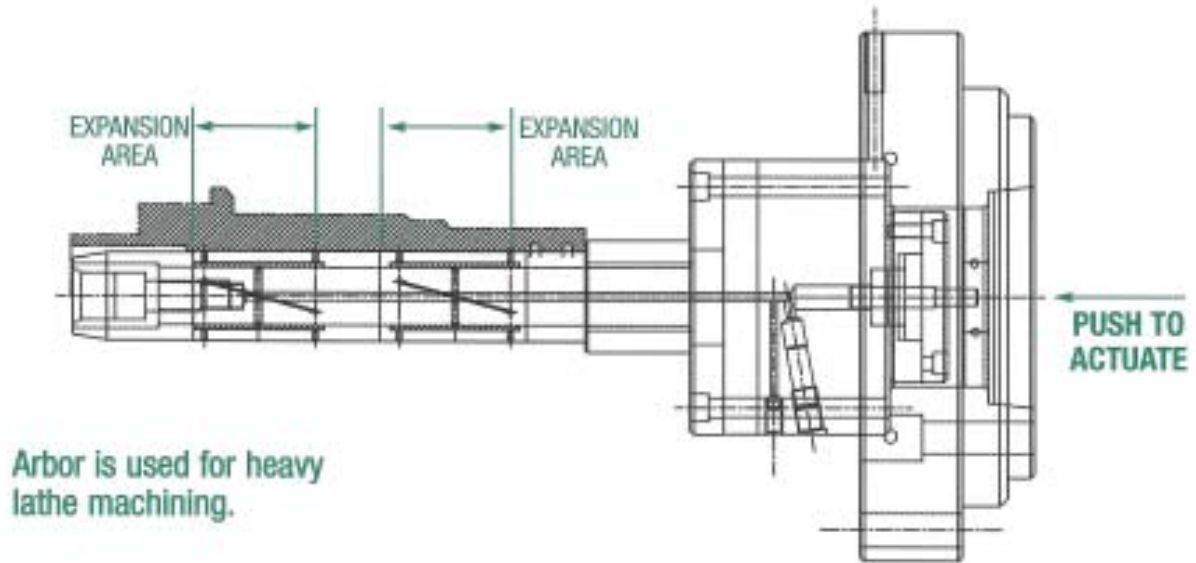

Ref. Design 9030

MANUALLY ACTUATED INSPECTION ARBOR

Mounted to Zero Spindle

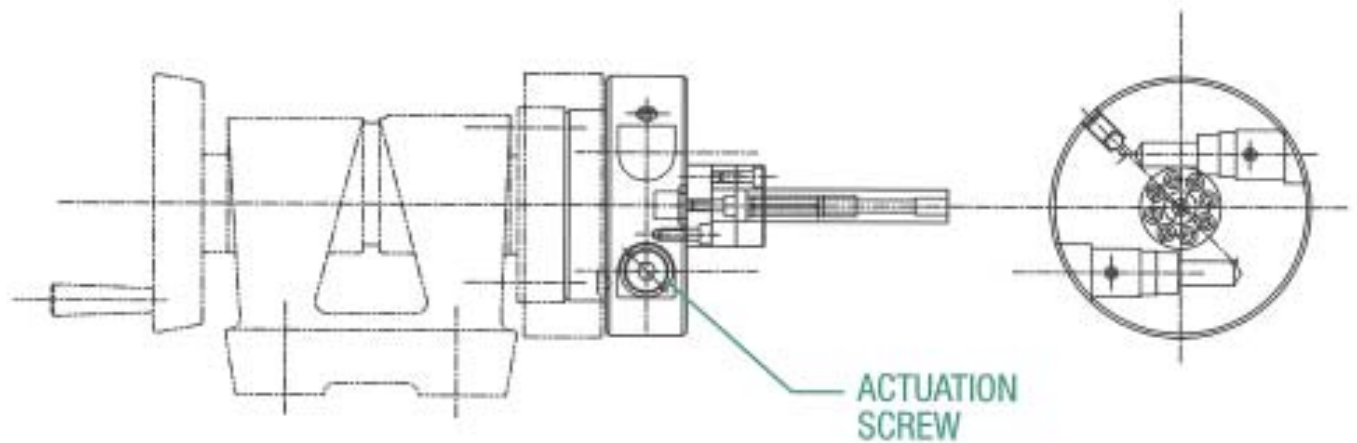

Ref. Design 9013

CHUCKS AND ARBORS

MANUALLY ACTUATED BETWEEN CENTERS GRINDING ARBOR (SPLINED P.D. GRIP)

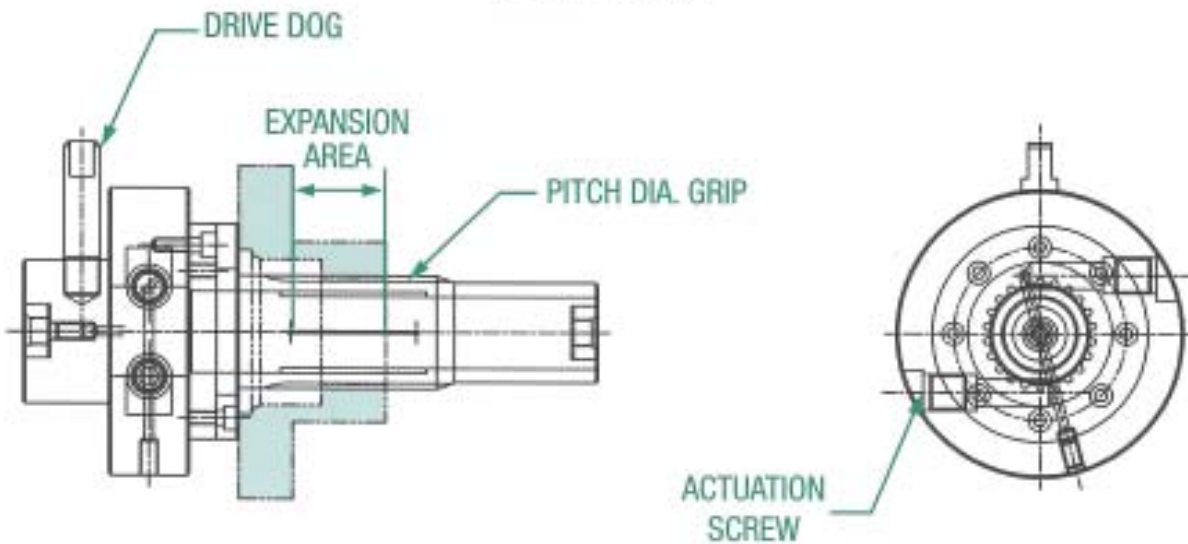

Ref. Design 9012

EXTERNAL POWER SOURCE ACTUATED ARBOR

Mounted to Machining Center Index Table

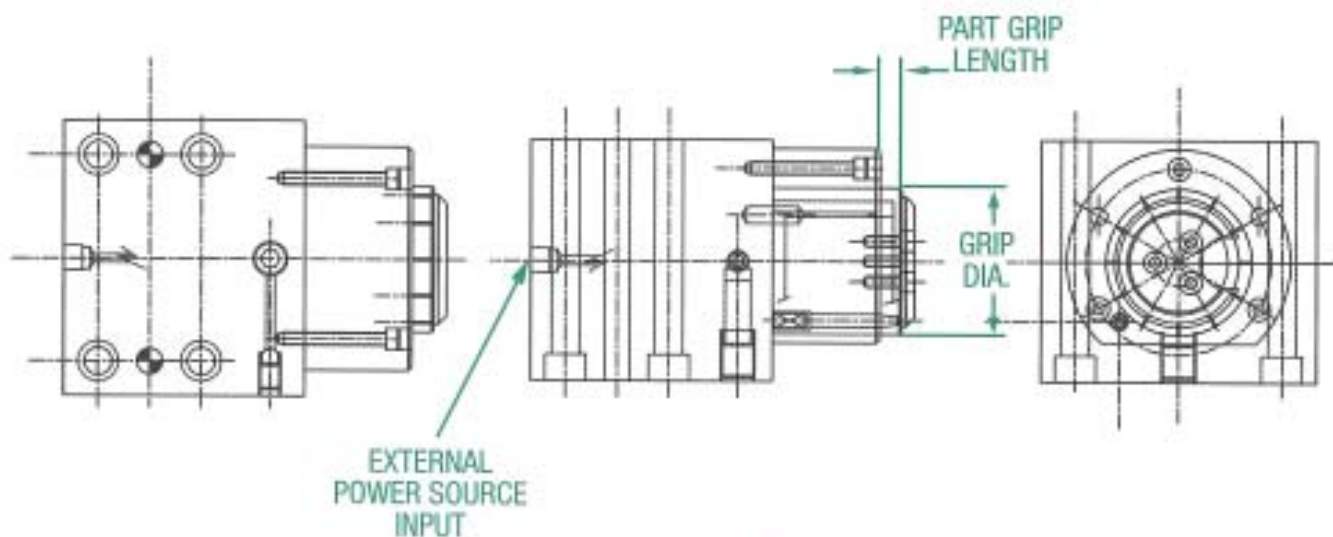

Ref. Design 9022

CHUCKS AND ARBORS

SPLINED PITCH DIAMETER GRIP ARBOR

Drawbar Actuated

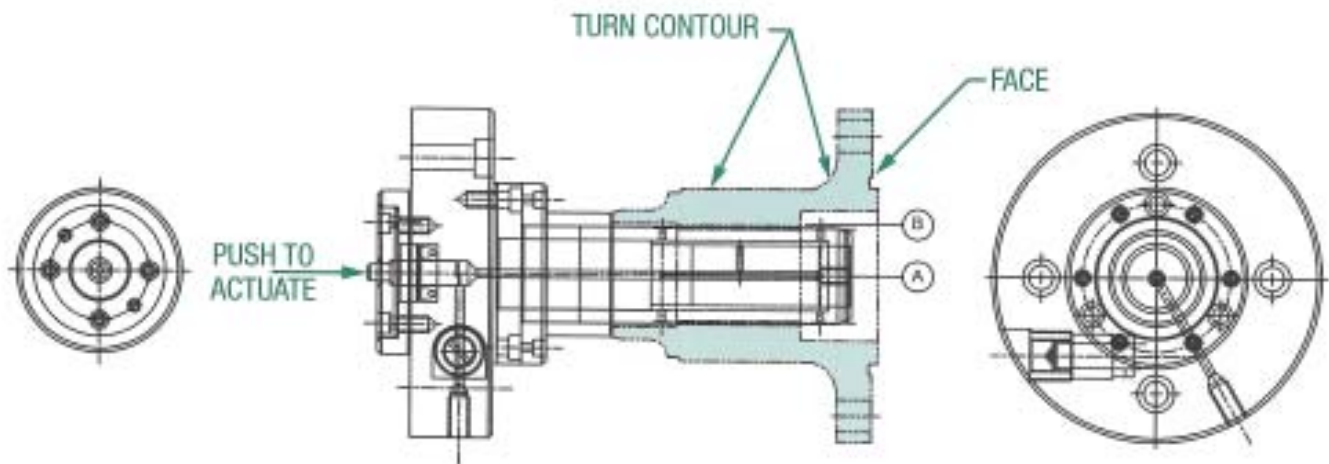

Ref. Design 9025

DRAWBAR PROBE ACTUATED SPLINED ARBOR

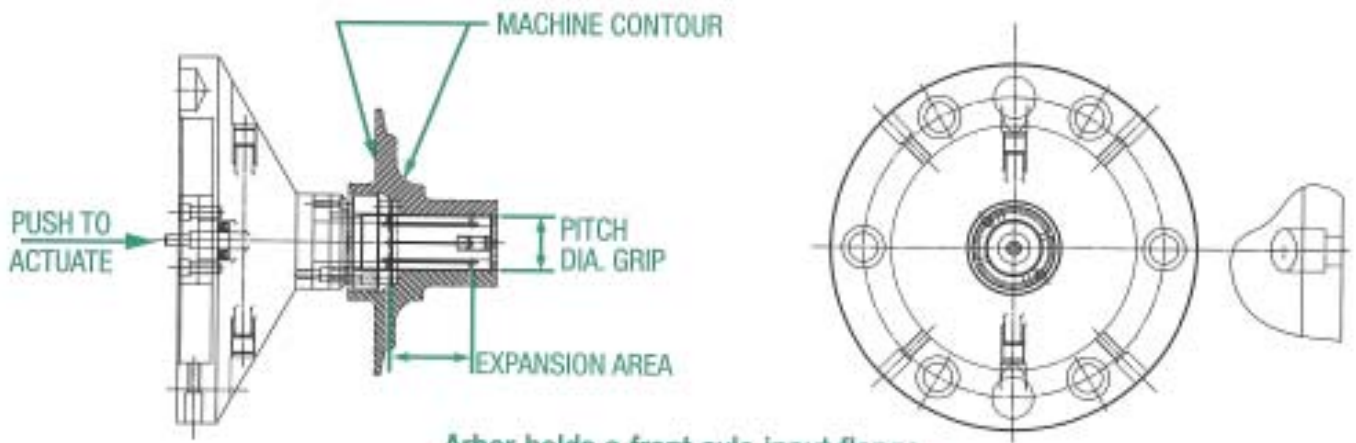

Arbor holds a front axle input flange.

Ref. Design 8765B-96

CHUCKS AND ARBORS

MULTI-GRIP MANUALLY ACTUATED GRIND ARBOR

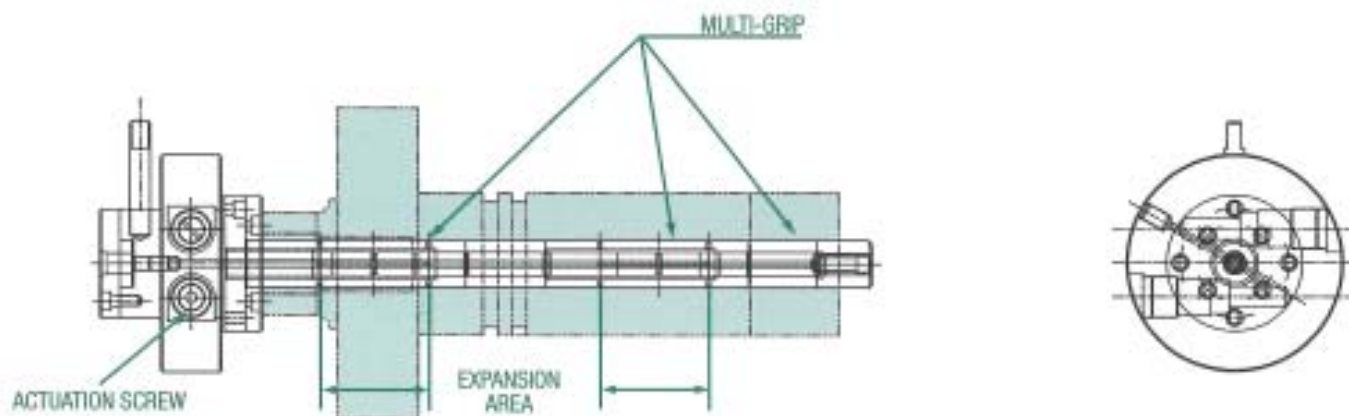

Ref. Design 9019

AUTOMOTIVE FLYWHEEL BALANCE ARBOR

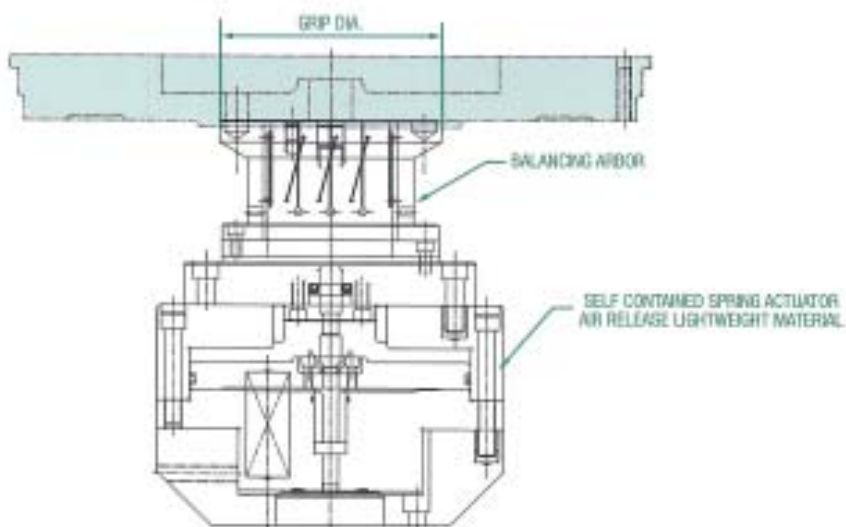

Ref. Design 9018

CHUCKS AND ARBORS

OPERATION – GUN DRILL HYDRAULIC O.D. GRIP CHUCK

External Power Source Activated

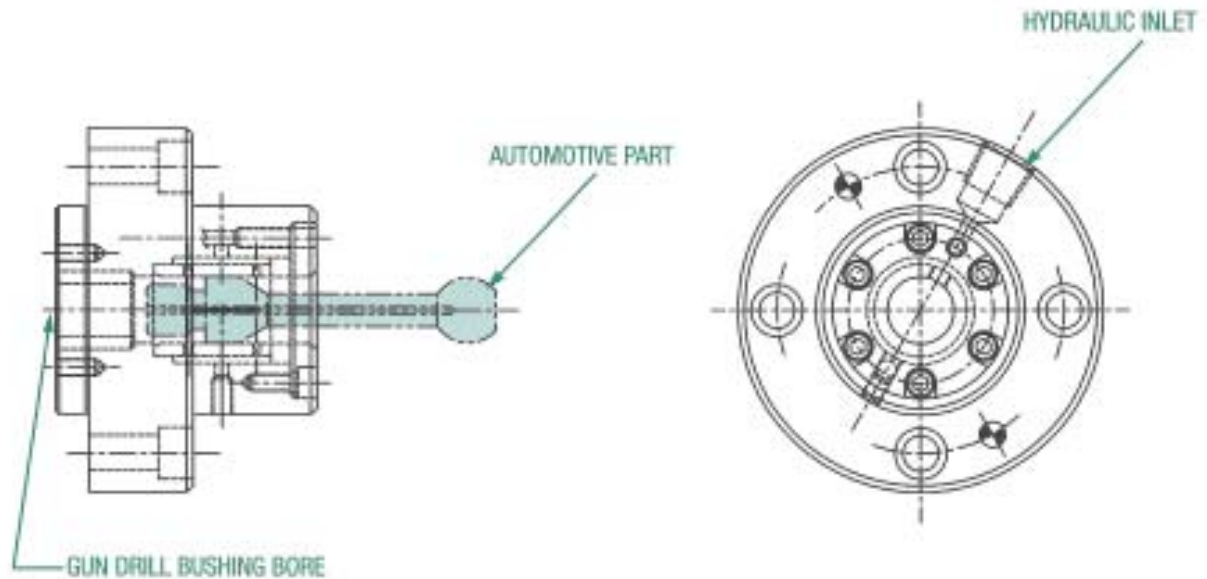

Ref. Design 9006

HSK TOOL HOLDER BALANCING CHUCK

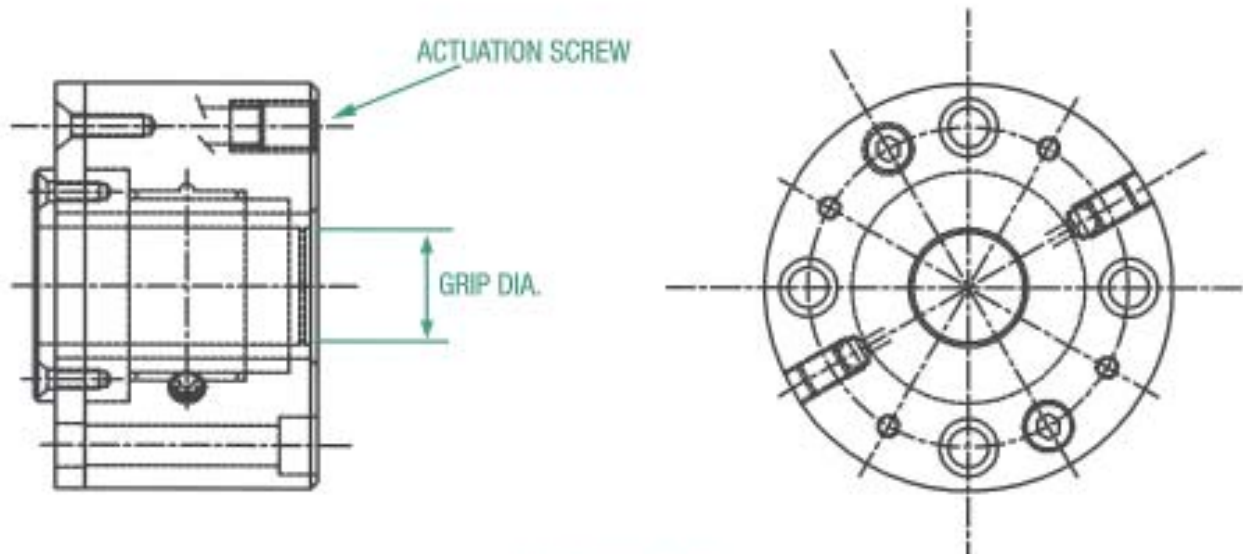

Ref. Design 9011

CHUCKS AND ARBORS

INTENSIFIER ASSISTED HYDRAULIC ARBOR

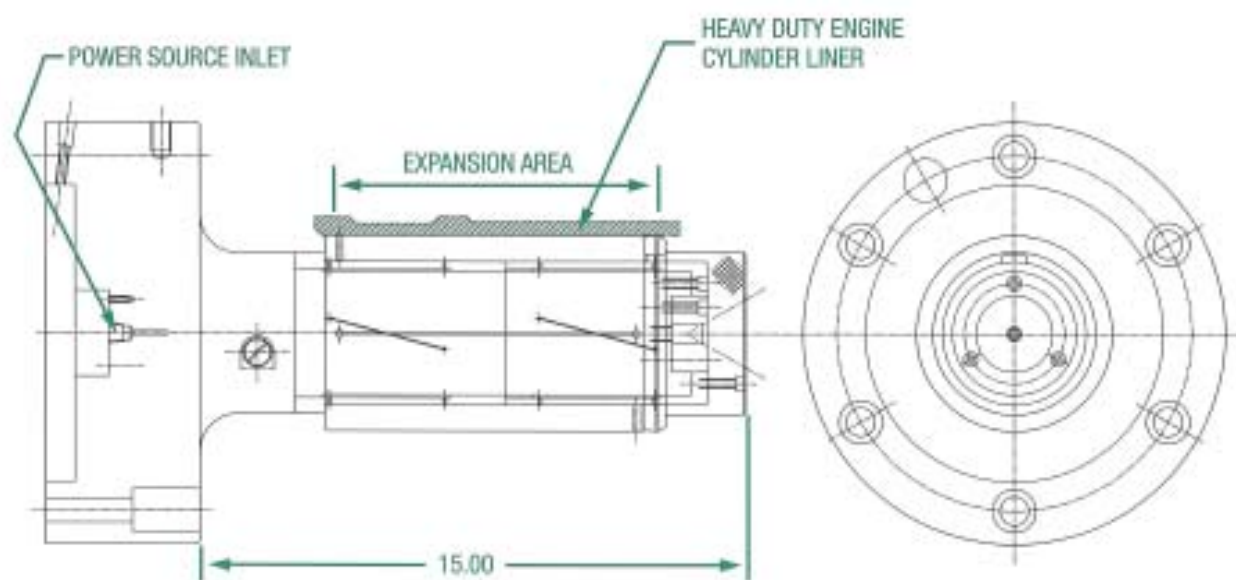

Ref. Design 8535

HYDRAULIC TAILSTOCK CENTERING ARBOR

For Automotive Axle Machining

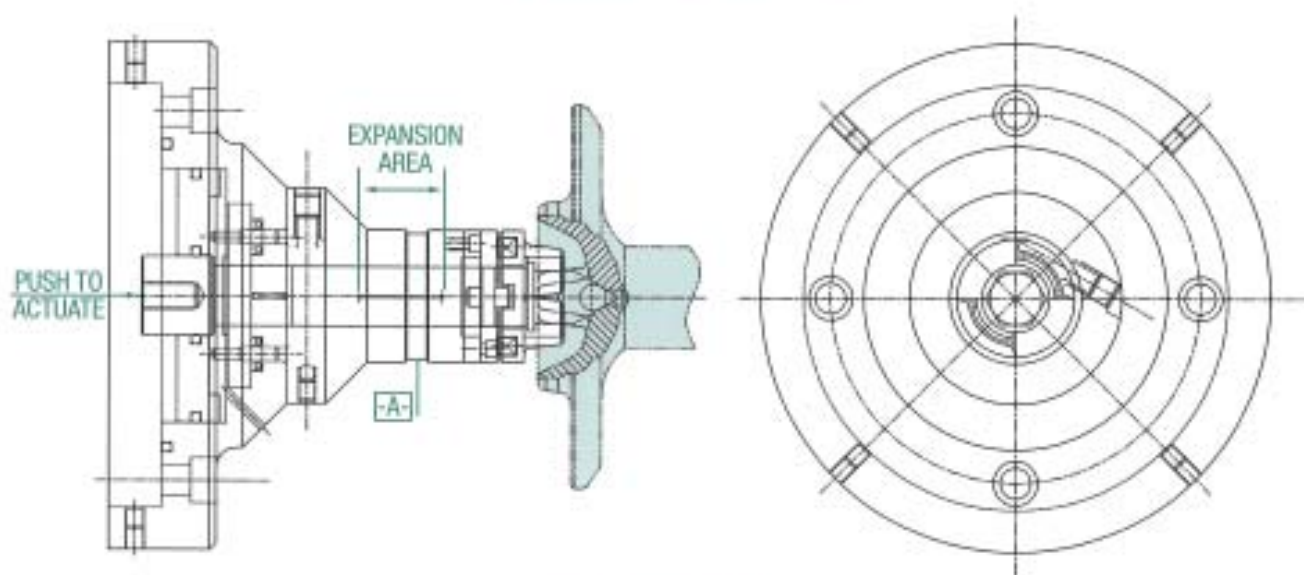

Ref. Design 8780

THE CAMERON INTENSIFIER

The purpose of the **Cameron Intensifier** is to multiply an existing machine hydraulic system (where no mechanical advantage is available such as a drawbar) in order to create higher P.S.I. workholding capabilities.

Example of Intensifier output (P.S.I.) Ref 10:1 ratio 250 P.S.I. inlet pressure to intensifier = approximately 2500 P.S.I. outlet pressure to arbor.

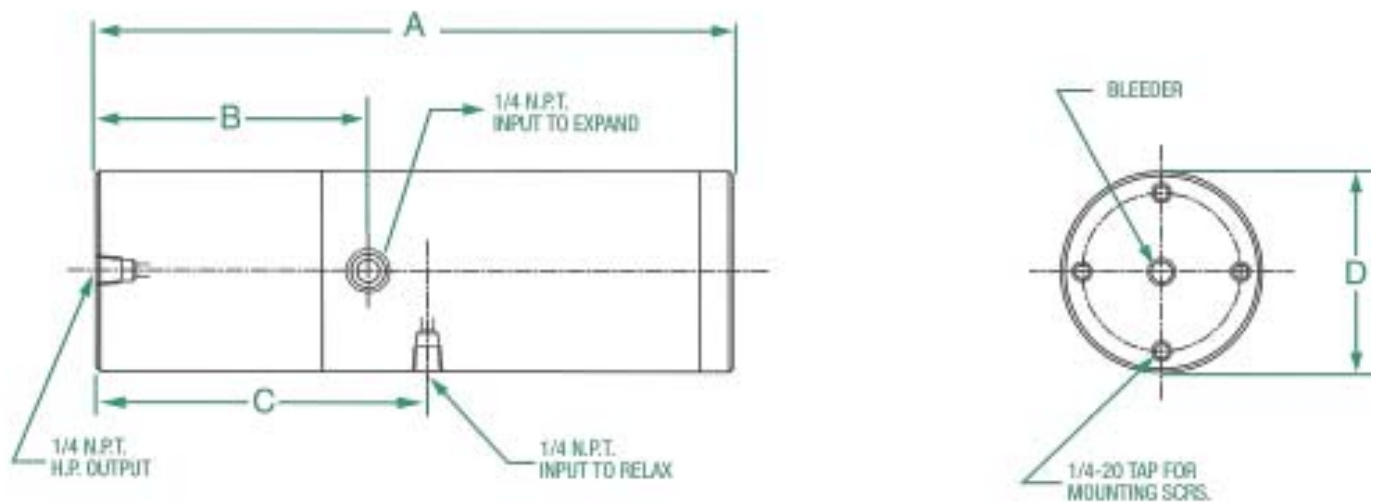

TOOL NO.	A DIM	B DIM	C DIM	D DIM
3711-.312-1.9 10:1 RATIO	9.50	4.06	4.94	2.38
3711-.312-1.9-16 16:1 RATIO	9.50	4.06	4.94	2.50
3711-.312-2.9 10:1 RATIO	11.50	5.06	5.94	2.38
3711-.562-1.9 10:1 RATIO	9.50	4.06	4.94	3.00
3711-.312-2.9 10:1 RATIO	11.50	5.06	5.94	3.00
3711-.750-6.12 5.4:1 RATIO	17.12	7.81	8.68	4.00

NOTE: High Pressure output is normally 1800-2800 PSI, depending on required tightness of grip. Input to expand pressure is normally 250-500 PSI, which determines the output for H.P. (see "Ratio" under Tool No.). Input to relax pressure approximately 300 PSI.

Speedgrip Chuck, Inc.

Speedgrip Chuck, Inc. designs and manufactures a full line of internal and external gripping collet chucks, diaphragm chucks, and between center mandrels. Air and hydraulic cylinders are available to compliment our workholding lines.

www.speedgrip.com



Cameron

Cameron designs and builds custom internal and external hydraulic chucks and arbors with collet chucks from our Sabertooth line.

www.cameron-workholding.com

Madison Face Driver

The Madison Face Driver division offers a wide variety of standard drivers and pins along with special design face drivers. Featuring the Hydra-Drive line for extreme accuracy requirements.

www.facedrivers.com



Cameron
2000 Industrial Parkway
Elkhart, IN 46515
(574) 294-1506 • FAX: (574) 294-2465
e-mail: salesweb@speedgrip.com